

TAPTONE

REJECTORS

Sorting, Distribution,
and Rejection
Systems Include:

- Large Container, Small Container and Case Systems
- Hard Reject and Soft Reject Systems



TELEDYNE TAPTONE
Package Inspection Systems
A Teledyne Technologies Company

www.TapTone.com

SYNCHRON 30/50

Linear Sorting, Distribution and Rejection System

The SYNCHRON systems ensure the standing transfer of containers independent of the shape and material of the container. This allows for use on filling lines with containers of different shapes, diameters, height and weight without mechanical or electrical adjustments of the rejection system. Each system includes a rejection station and a control cabinet.

Features

- High Speed Rejection/Distribution
- Guaranteed Standing Distribution/Rejection Eliminates Cleanup Due to Spilled Liquids
- Single System for Plastic, Glass, and Metal Containers
- Automatic Synchronization to Conveyor Speeds
- Transfer to Rejection Conveyor without Changing Direction or Speed

How It Works

When a reject signal is received, the control system activates controlled rejector segments in a progressive sequence to smoothly transfer the container off the main conveyor. With consecutive rejects, the segments remain extended in their active position.



System Specifications

| | |
|-------------------------------|--|
| Performance | SYNCHRON 30; 500 containers/min SYNCHRON 50; 800 containers/min |
| Container Types | Plastic, glass, metal |
| Spacing Distance | 3/4 in (1.9 cm) |
| Displacement | 4 7/10–5 1/10 in (12 cm / 13 cm) |
| Electrical | 110/240 VAC, 50/50 Hz 380/460 VAC, 50/60 Hz |
| Air | 80–120 psi (6–8 bar) |
| Material | Stainless Steel, IP 56 (rejection unit), IP65 (Control Cabinet) |
| Weight lbs/kg | SYNCHRON 30; 440 lb/200 kg SYNCHRON 50; 660 lb/300 kg |
| Dimensions (LxWxH) ... | SYNCHRON 30 Rejection Station 39 in x 21 in x 19 in (100 cm x 53 cm x 49 cm) |
| | SYNCHRON 50 Rejection Station 62 in x 21 in x 24 in (157 cm x 53 cm x 60 cm) |
| | Control Cabinet (SYNCHRON 30/50) 30 in x 12 in x 30 in (76 cm x 30 cm x 76 cm) |

SYNCHRON 30

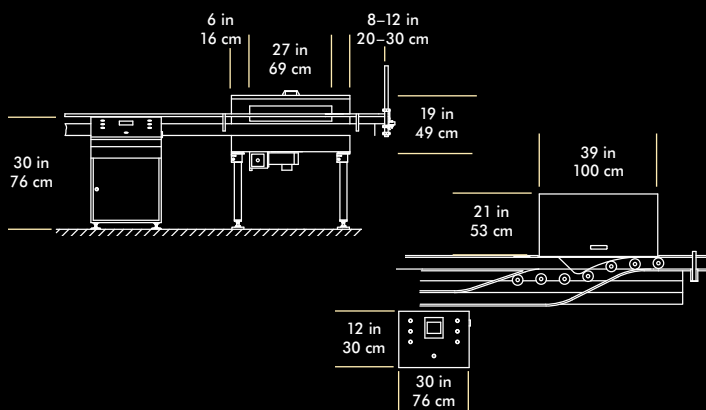

SYNCHRON 50

