

TAPTONE

REJECTORS

Sorting, Distribution,
and Rejection
Systems Include:

- Large Container, Small Container and Case Systems
- Hard Reject and Soft Reject Systems



TELEDYNE TAPTONE
Package Inspection Systems
A Teledyne Technologies Company

www.TapTone.com

CENTRO FLEX CENTRO FLEX 160

Sorting and Distributing System for Glass, Plastic, and Metal Containers

The CENTRO FLEX systems are all-purpose sorting and distributing systems for standing displacement of containers made of plastic, glass and metal at full conveyor speeds. The system can reject up to 800 containers per minute and requires less than 30 inches of conveyor space.

Features

- High Speed Rejection/Distribution
- Standing Rejection Reduces/Eliminates Clean Up Due to Spilled Liquids
- Conveyor Mounting Minimizes Installation Costs
- Minimal Space Requirement Enables Adaptation to Almost Any Production Line
- Single System for Plastic, Glass and Metal Containers
- Automatically Adjusts to Conveyor Speeds

How It Works

Fifteen pneumatically-extendable rejection segments are activated generating a curve outward to deflect the rejected bottle to the adjacent conveyor. As containers pass, each individual segment returns to its neutral or retracted position and does not affect the next container.



System Specifications

Performance	800 containers/minute maximum
Container Types	Plastic, metal and glass, weight: <5.5 lb (<2.5 kg)
Spacing	Approximately 1 1/2 in (3.8 cm)
Displacement	
Centro Flex	0–4 in (0–10 cm)
Centro Flex 160	0–6 in (0–15 cm)
Electrical	110/220 VAC, 50/60 Hz, 100 watts maximum
Air	Minimum: 80 psi (6 bar) Maximum: 200 psi (14 bar)
Material	Stainless Steel, NEMA 4X, IP54
Mounting	Conveyor mount
Weight	18 lb /24 lb (8 kg/11 kg)(rejector only)
Dimensions (LxWxH)	
Centro Flex	20 1/2 in x 6 1/3 in x 29 1/2 in (52 cm x 16 cm x 75 cm)
Centro Flex 160	26 in x 6 1/3 in x 29 1/2 in (66 cm x 16 cm x 75 cm)

CENTRO FLEX

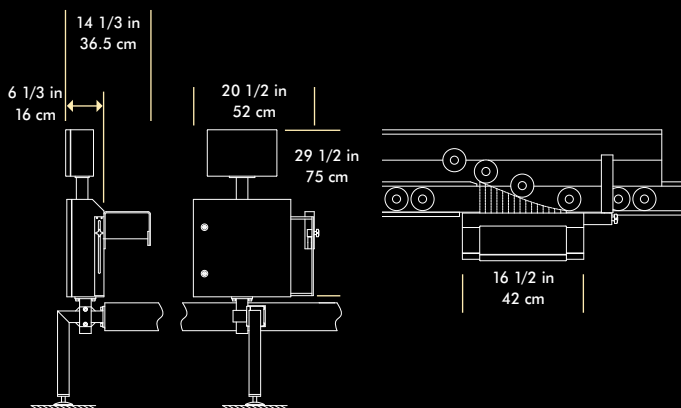

CENTRO FLEX 160

